

**IP65 Microwave dimming sensor for warehouse Model No.60759**

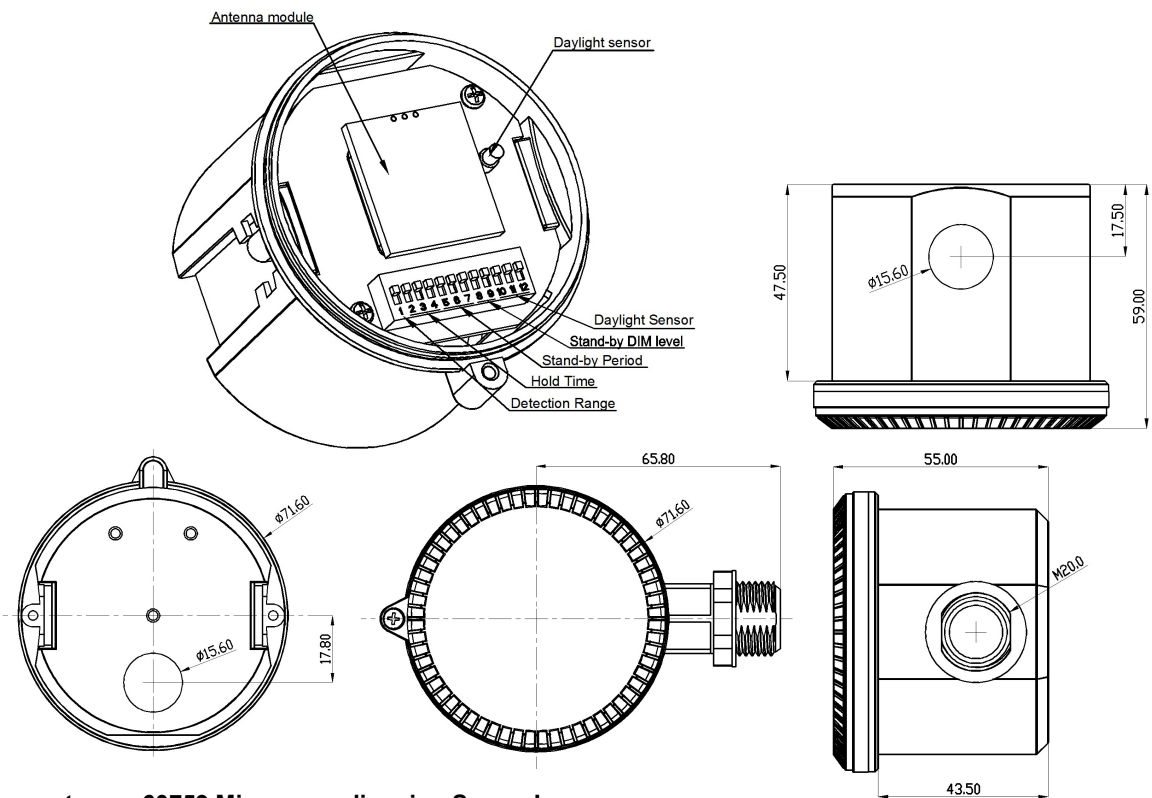

**Welcome to use 60759 Microwave dimming Sensor!**

The product is a new saving-energy switch; it adopts microwave sensor mould with high-frequency electro-magnetic wave (5.8GHz) and integrated circuit. It gathers automatism, convenience, safety, saving-energy and practicality functions. The wide detection field depends on detectors. It works by receiving human motion. When one enters the detection field, it can start the load at once and identify automatically day and night. Its installation is very convenient and its using is very wide. Detection is possible to go through doors, panes of glass or thin walls.

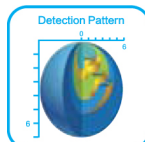
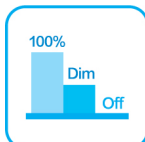

**SPECIFICATION:**

Voltage: 110-277V/AC

Detection Angle: 360°

Daylight sensor: 2lux, 10lux, 50lux,  
2000lux (choice)

Transmission Power: <0.2mW

Hold Time: 5s, 30s, 90s, 3min, 5min,  
10min, 20min, 30min (choice)

Stand-by Period: 10s, 1min, 5min, 10min,  
30min, 60min, +∞,0s (choice)

Stand-by DIM Level: 10%, 20%, 30%,  
50% (choice)

Power Frequency: 50/60Hz

Detection Range: 50%, 100%(choice)

Detection Distance: 4-10m (radius), adjustable

HF System: 5.8GHz CW radar, ISM band

Power Consumption: approx 0.9W

Detection Motion Speed: 0.6-1.5m/s

Installing Height: 4-15m

Rated Load: Max.2000W (220-277V/AC)

1000W (110-130V/AC)

1000W (220-277V/AC)

500W (110-130V/AC)



**FUNCTION:**

- Can identify day and night: It can work in the daytime and at night when three knobs are on above position (Daylight Sensor 2000Lux). It can work in the ambient light less than 2LUX when three knobs are on below position (Daylight Sensor 2Lux). As for the adjustment pattern, please refer to the testing pattern.
- Hold time is optional. It can be set according to the consumer's desire. The minimum time is 5sec.The maximum is 30min.
- It offers 3 levels of light: 100 %--> dimmed light (10%, 20%, 30%, 50% optional) -->off; and 2 periods of selectable waiting time, motion hold time and stand-by period; selectable LUX value and choice of detection area.

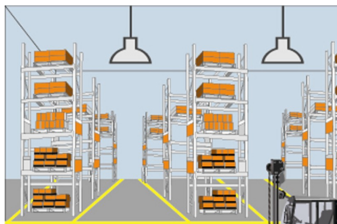

With sufficient ambient light, the sensor does not switch on the lamp.

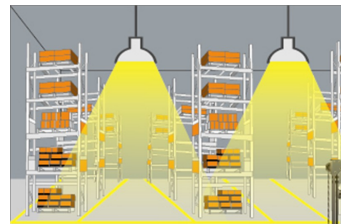

With insufficient ambient light, the sensor switches on the lamp when motion is detected.

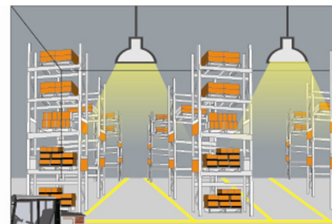

After hold time, the sensor dims the lamp at a low light level if no new motion trigger.

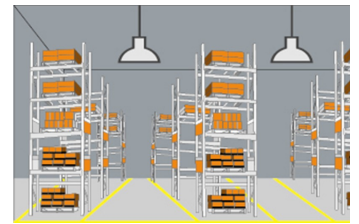

After stand-by period, the sensor switches off the lamp if no motion is detected in its detection zone.

**NOTE:** the high-frequency output of the HF sensor is <0.2mW- that is just one 5000<sup>th</sup> of the transmission power of a mobile phone or the output of a microwave oven, the baby can't touch it.

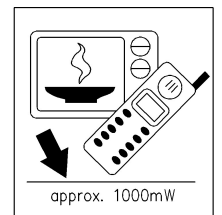
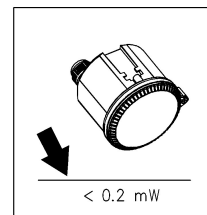

**SENSOR INFORMATION**

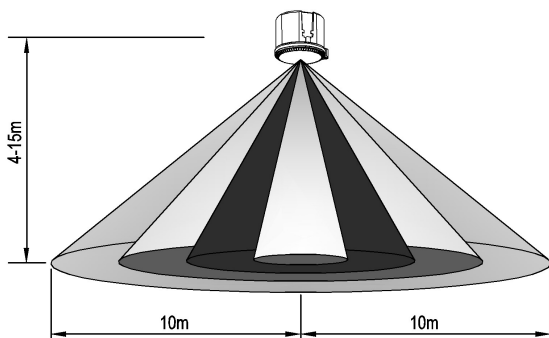

Height of installation: 4-15m

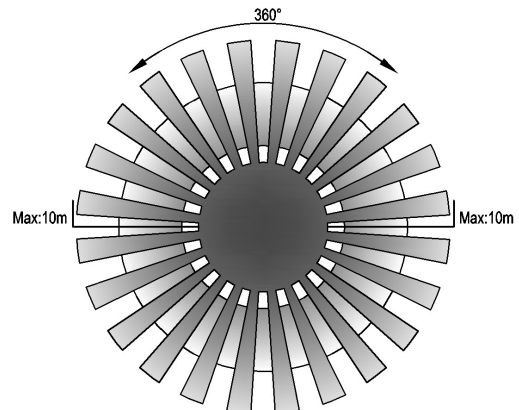

Detection Distance: Max.10m (radius)

**SETTING:**

**Detection Range**

Detection distance can be set with different combinations of DIP switches to precisely fit for each specific application

**Hold Time**

Hold Time means the time period you would like to keep the lamp on 100% after the person has left the detection distance

**Stand-by Period**

This time period you would like to keep at the low light output level before it is completely switched off in the long absence person

**Note:** “+∞” means fixture keeps on stand-by dimming level and never switches off.

”0s” means no dimming function

**Stand-by DIM level**

This is dimmed low light control light output level you would like to have after the hold time in the absence person

**Daylight Sensor**

The LUX value can be set on DIP switches in order to fit different ambient light.

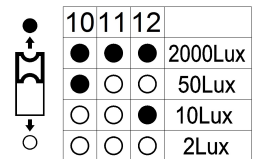
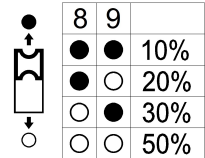
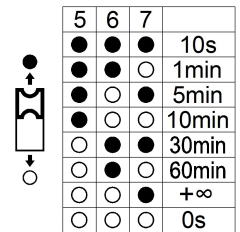
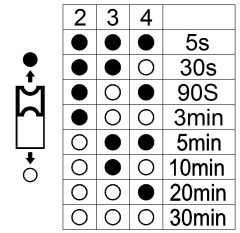
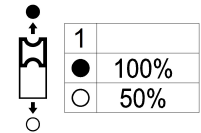

**CONNECTION-WIRE DIAGRAM:**

**1、 60759A**

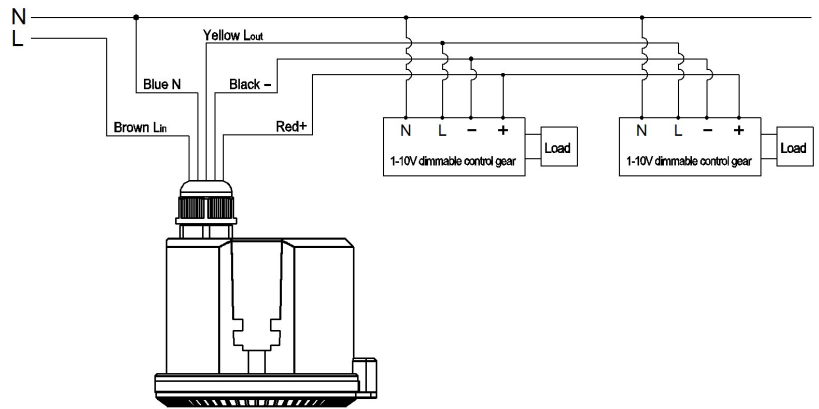
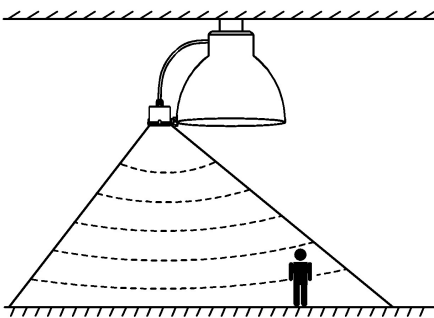

**2、 60759B**

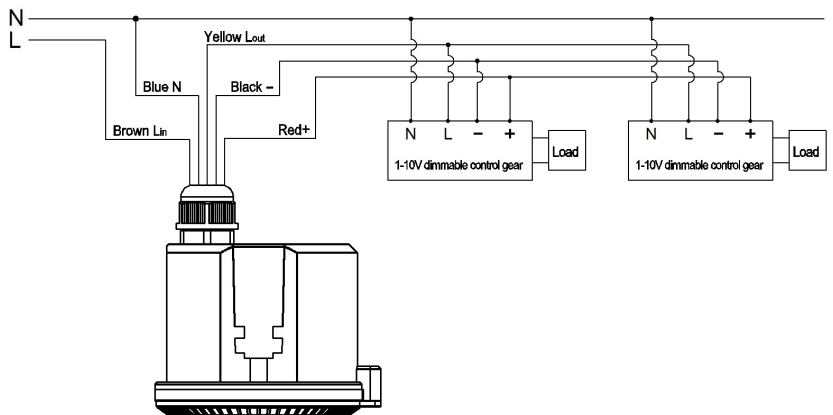
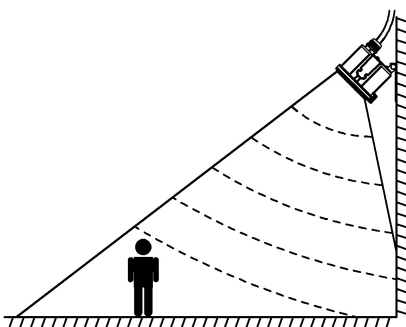

**3. 60759C**

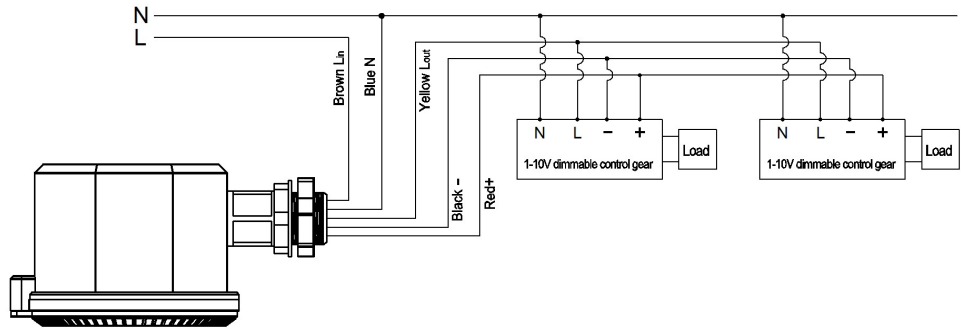
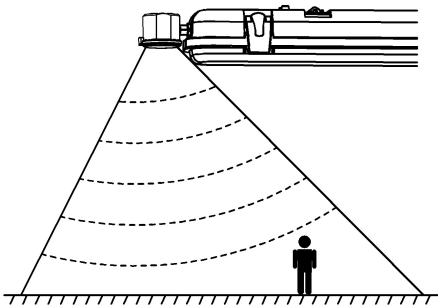

**4. 60759D**

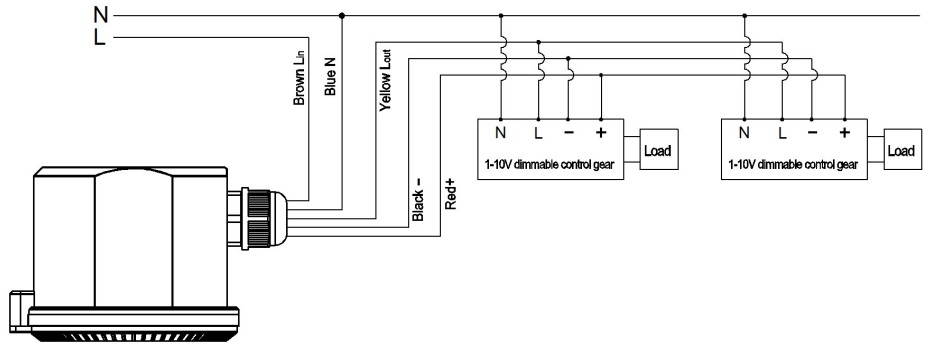
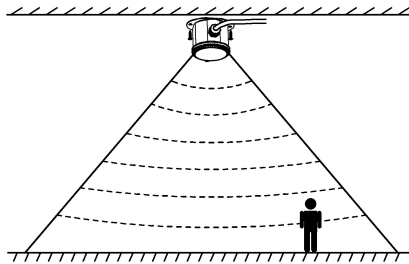

**Remarks:** When you install sensor, please keep it parallel to the ground as above pictures.

**TEST:**

- Slide the all knobs on "above" position. When you switch on the power, the light will be on at once, and 5 sec later without induction signal the light will turn off quickly. Then if the sensor receives induction signal, it can work normally
- Adjust the stand-by period to "10s", when the sensor receives induction signal, the light will be 100% on; 5sec later, the light dims quickly to 10% on for 10sec and then turn off. If the sensor receives second induction signal within the stand-by period, the light will be 100% on.

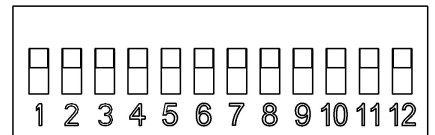

1	Detection Range			Hold Time			Stand-by Period			Stand-by DIM level			Daylight Sensor		
	●	○	○	●	●	○	●	●	○	●	○	○	●	○	○
100%	5s	10s	10%	2000Lux	2	3	4	5	6	7	8	9	10	11	12
50%	30s	1min	20%	50Lux	30s	5min	30%	10Lux	3min	10min	50%	10Lux	10min	60min	2Lux
	90s	3min			5min	30min			10min	20min					
					20min	+∞									
					30min	0s									

**NOTES:**

- Electrician or experienced human can install it.
- Can not be installed on the uneven and shaky surface
- In front of the sensor there shouldn't be obstructive object affecting detection.
- Avoid installing it near the metal and glass which may affect the sensor.
- For your safety, please don't open the case if you find hitch after installation.
- In order to avoid the unexpected damage of product, please add a safe device of current 6A when installing microwave sensor, for example, fuse, safe tube etc.
- Motion sensor overrides daylight sensor, meaning the daylight sensor starts to check the ambient natural light only when the lamp is switched off (motion hold-time elapsed).
- This 1-10V output is no insulated; please make sure the fixture is constructed according to relevant safety standard.

**SOME PROBLEM AND SOLVED WAY:**

- The load doesn't work:
  - a. Check the power and the load.
  - b. Whether the indicator light is turned on after sensing? If yes, please check load.
- The sensitivity is poor:
  - a. Please check if in front of the sensor there shouldn't be obstructive object that affect to receive the signals.
  - b. Please check if the signal source is in the detection fields.
  - c. Please check the installation height.